

# DOME

since 2001

Changzhou Dome Abrasives Manufacture Co.,Ltd



MORE THAN

24

YEARS OF  
ABRASIVE  
MANUFACTURING  
EXPERIENCE

## About Dome

---

founded in

**2001**

---

cover an area of

**20,000** square meters

---

certificates

**ISO9001, EN12413**



**01**

About Dome



**02-03**

Label Instruction



**04-10**

Cutting disc



**11-13**

Grinding disc



**14-15**

Flap disc



**16-17**

Mini model



**18**

Packaging



**19-21**

Certificate



## Changzhou Dome Abrasives Manufacture Co.,Ltd

### An abrasive manufacturer you can trust

Dome Abrasives was established and registered in 2001. We have more than 24 years experience in developing and manufacturing resin bond cutting and grinding wheels.

We now have nearly 100 sets of production equipment and a modern production workshop covering an area of 20,000 square meters, which can fully meet your needs.

As a star company, all our products have passed ISO9001, MPA, CE, BSCI certificate and EN12413 standard. Dome has always been committed to providing customers with cost-effective products and has won the praise of users for its continuous innovation and excellent customer service. We export to the South America, Middle East, Southeast Asia, Europe and America, etc., and our products are all over the world.

Dome ambition is to become one of the leading market share holder in the most competitive Market in the world today.

"Customer' s goal and satisfactions are our first priority."



#### DOME Website

You will receive more information on the CNDOME brand here or at [www.czdome.com](http://www.czdome.com)



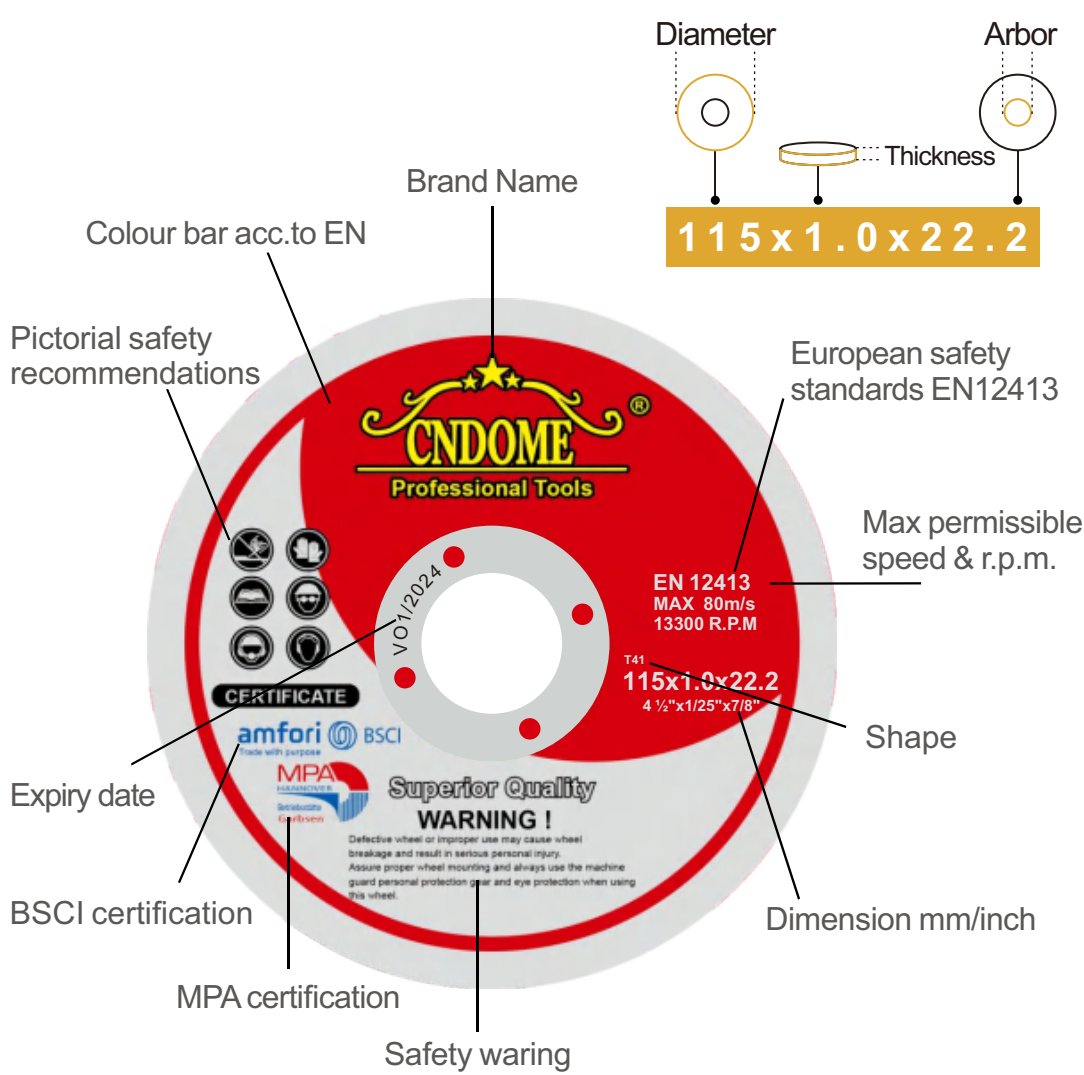

Colour coding for the four product lines



## Abrasive

- A Aluminium Oxide
- GC Green Silicon Carbide
- C Black Silicon Carbide
- WA White Aluminium Oxide
- ZA Zirconia

## Grade

- H-K soft
- L-I medium
- P-S hard
- T-Z very hard

## Grain Size

- 16-24 coarse
- 30-60 medium
- 70-220 fine-medium

## Bond

- BF=Resinoid bond
- Fibre=reinforced, woven or ono-woven

## Safety Recommendations

- Not approved for side grinding!
- Wear protective gloves!
- Observe safety recommendations!
- Wear protective goggles!
- Wear dust respirator!
- Wear ear protectors!

## Grinding safety

Abrasive manufacturers, machine producers and users all contribute to grinding safety. DOME abrasives are built to meet the prescribed safety codes. However, the user is responsible for proper handling of the abrasive drive and correct use and application of the grinding abrasives.

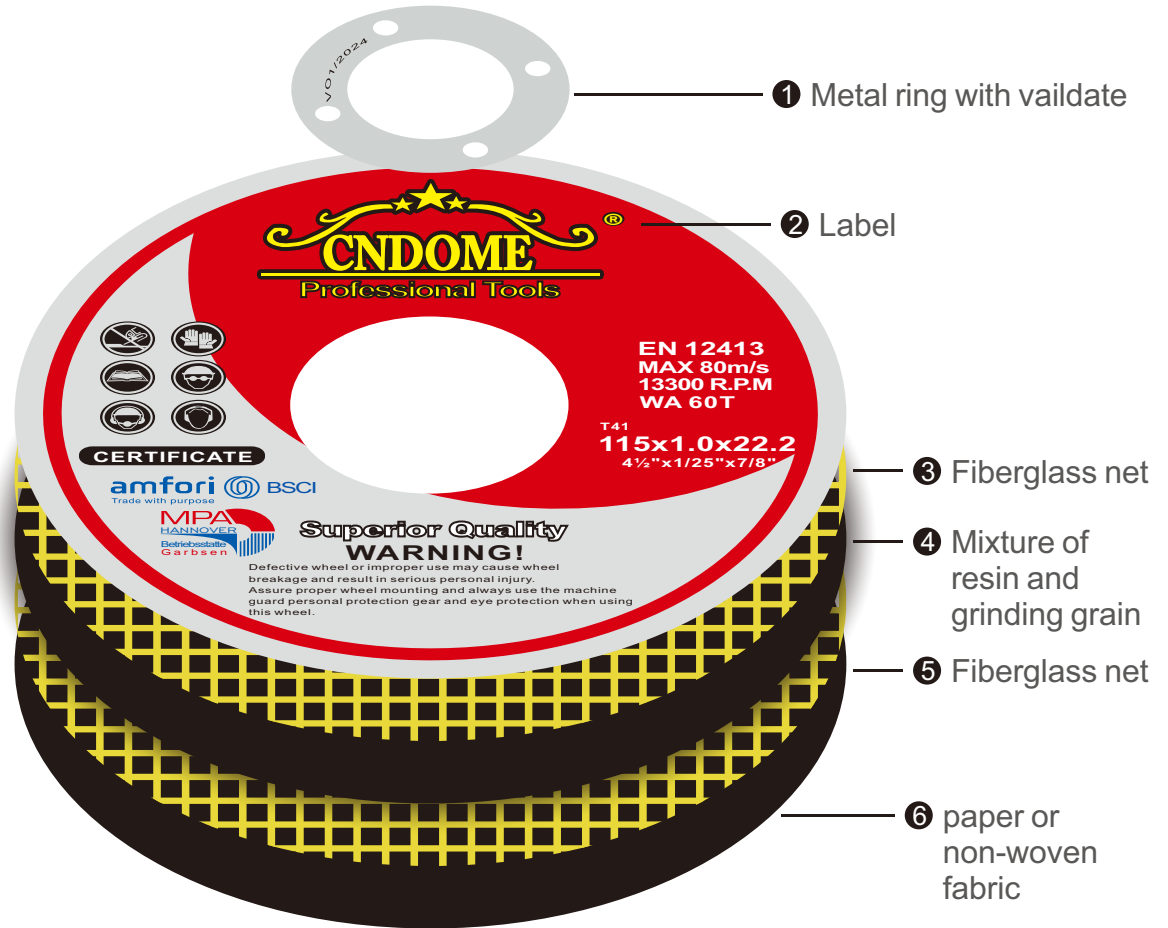

## Metal ring with validity date

Example:

V01/2024 indicates production in January of 2021 and advised usage before January of 2024

## Fiberglass net

Tolerance range of OD<1mm, tolerance rang of ID<0.5mm.

Above mentioned sizes are common spcifications, special sizes can be produced according to customers requirement with OD range 32~1300mm and ID range 7~130mm.

## Dimensions and shape

The diameter, thickness and center hole size and their meanings are shown in the figure:

A(=Diameter), B(=Thickness), C(=Arbor)

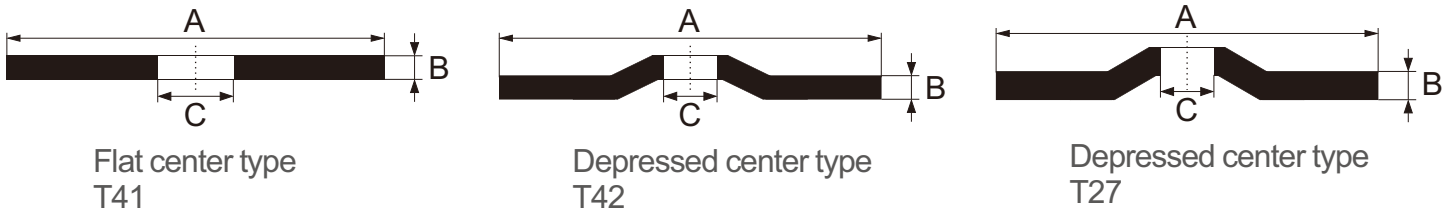

Never use two flanges that have different diameters for cutting and grinding, must be assured that the two flanges have the same diameters and support areas.



# Cutting disc

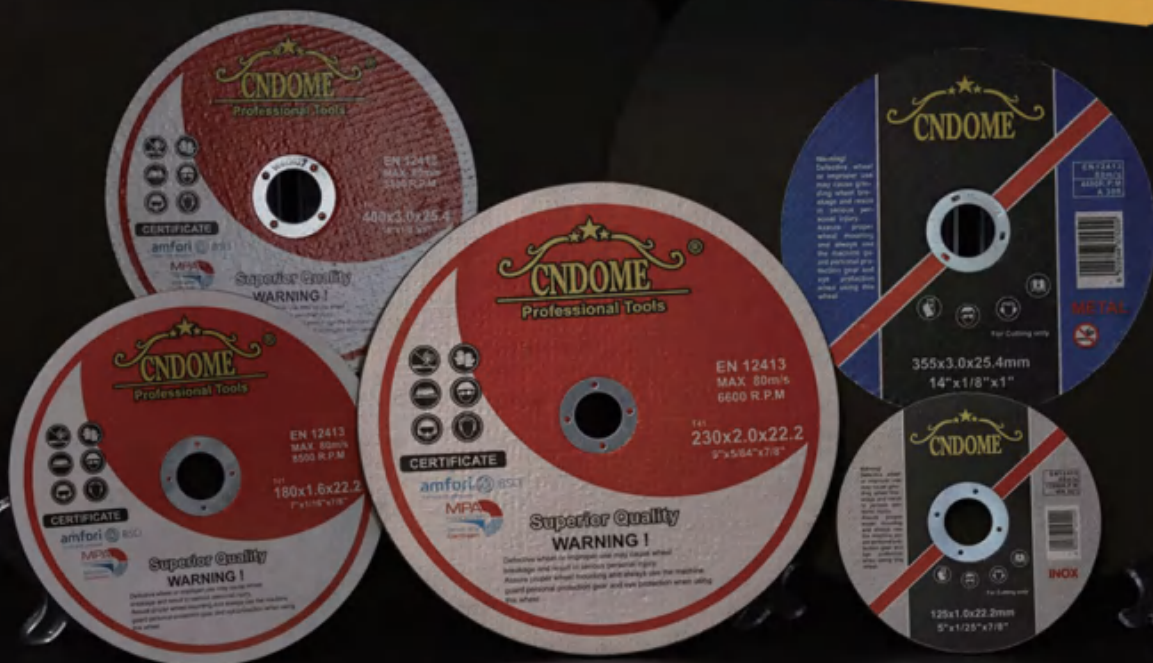

## Full size cutting disc

- Very long durability
- Easy working
- Cost effective
- Less heat generated
- Less noise
- Minimal burrs on the surface

## Application

- Stainless steel/INOX
- High alloy special steel
- Angular steel profiles
- Very solid construction steel
- Iron
- Solid steel bar
- Unalloyed and alloyed construction steel

**EN12413**

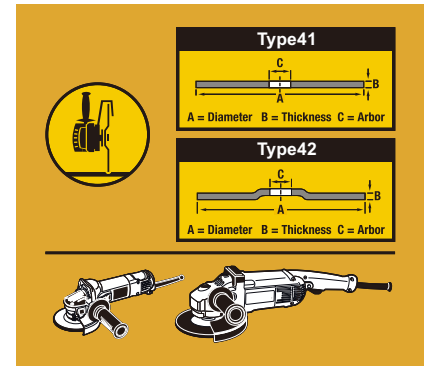

## CNDOME Full size cutting disc



	DimensionD*T*A(mm)	DimensionD*T*A(inch)	Shape	Speed(R.P.M.)	Speed(m/s)	PCS/Shrink wrap	PCS/Inner box	PCS/Outer carton
2 inch	50x1.0x10	2x1/24x3/8	T41	20100	80	25	50	800/1200
	58x1.0x10	2x1/24x3/8	T41	20100	80	25	50	800/1200
3 inch	75x0.8x10	3x1/32x3/8	T41	20100	80	25	50	800/1200
	75x1.0/1.2x10	3x1/24x3/8	T41	20100	80	25	50	800/1200
	75x1.6x10	3x1/16x3/8	T41	20100	80	25	50	800/1200
4 inch	100x2.0x16	4x1/12x5/8	T41	15200	80	25	50	400
	100x3.0x16	4x1/8x5/8	T41	15200	80	25	50	400
	105/107x1.0x16	4x1/25x5/8	T41	15200	80	25	50	800
	105/107x1.2x16	4x3/64x5/8	T41	15200	80	25	50	800
4.5 inch	105/107x1.6x16	4x1/16x5/8	T41	15200	80	25	50	800
	115x1.0x22.2	4 1/2x1/25x7/8	T41	13300	80	25	25	400
	115x1.2x22.2	4 1/2x3/64x7/8	T41	13300	80	25	25	400
	115x1.6x22.2	4 1/2x1/16x7/8	T41	13300	80	25	25	400
	115x2.0x22.2	4 1/2x1/12x7/8	T41	13300	80	25	25	400
5 inch	115x3.0x22.2	4 1/2x1/8x7/8	T41	13300	80	25	25	400
	125x1.0x22.2	5x1/25x7/8	T41	12200	80	25	25	400
	125x1.2x16	5x3/64x5/8	T41	12200	80	25	25	400
	125x1.2x22.2	5x3/64x7/8	T41	12200	80	25	25	400
	125x1.6x22.2	5x1/16x7/8	T41	12200	80	25	25	400
	125x2.5x22.2	5x3/32x7/8	T41/T42	12200	80	10	50	200
6 inch	125x3.0x22.2	5x1/8x7/8	T41/T42	12200	80	10	50	200
	150x1.6x22.2	6x1/16x7/8	T41	10200	80	25	25	400
	150x2.0x22.2	6x1/12x7/8	T41	10200	80	25	25	200/300/400
	150x3.0x22.2	6x1/8x7/8	T41	10200	80	25	25	200/300/400

	DimensionD*T*A(mm)	DimensionD*T*A(inch)	Shape	Speed(R.P.M.)	Speed(m/s)	PCS/Shrink wrap	PCS/Inner box	PCS/Outer carton
7 inch	180x1.6x22.2	7x1/16x7/8	T41	8500	80	10	20	200
	180x2.0x22.2	7x1/12x7/8	T41	8500	80	20	20	200
	180x3.0x22.2	7x1/8x7/8	T41	8500	80	20	20	200
9 inch	230x1.6x22.2	9x1/16x7/8	T41	6600	80	5	25	100
	230x2.0x22.2	9x1/12x7/8	T41	6600	80	5	25	100
	230x3.0x22.2	9x1/8x7/8	T41/T42	6600	80	5	25	100
10 inch	250x2.5x25.4	10x3/32x1	T41	6150	80	5	25	100
	250x3.0x25.4	10x1/8x1	T41	6150	80	5	25	100
12 inch	305x2.0x25.4	12x1/12x1	T41	5100	80	5	25	100
	305x2.5x25.4	12x3/32x1	T41	5100	80	5	25	100
	305x3.0/3.2x25.4	12x1/8x1	T41	5100	80	5	25	100
	305x3.5x25.4	12x9/64x1	T41	5100	80	5	25	100
	305x3.8x25.4	12x5/32x1	T41	5100	80	5	25	100
· Special sizes of Arbor are available: 15.87(5/8")/19.05(3/4")/20(3/4")/22(7/8")/32(5/4")								
14 inch	355x2.0x25.4	12x1/12x1	T41	4400	80	5	25	100
	355x2.5x25.4	12x3/32x1	T41	4400	80	5	25	100
	355x3.0/3.2x25.4	12x1/8x1	T41	4400	80	5	25	100
	355x3.5x25.4	12x9/64x1	T41	4400	80	5	25	100
	355x4.0x25.4(Rail)	12x5/32x1	T41	4400	80	5	25	100
· Special sizes of Arbor are available: 15.87(5/8")/19.05(3/4")/20(3/4")/22(7/8")/32(5/4")								
16 inch	405x3.0/3.2x32	12x1/8x5/4	T41	3800	80	5	25	100
	405x3.5x32	12x9/64x5/4	T41	3800	80	5	25	100
	405x3.8x32	12x5/32x5/4	T41	3800	80	5	25	100
	405x4.0x32	12x5/32x5/4	T41	3800	80	5	25	100
· Special sizes of Arbor are available: 25.4(1")								





## · Ultra-thin cutting disc ★★★★★

- Ultra thin design
- Precision cutting
- Top raw materials
- Excellent stock removal rate
- Optimum efficiency
- Over 30% more service-life

### Application

- Stainless steel/INOX
- Steel tube
- Iron
- Solid steel bar
- Angle steel
- Structural steel

**EN12413**

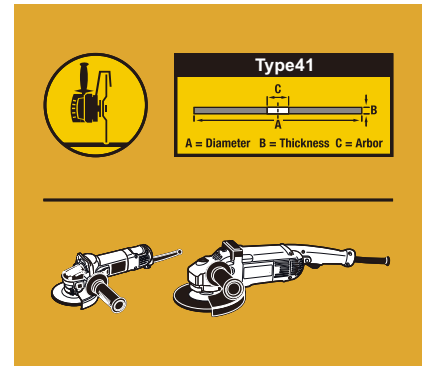

### Ultra-thin cutting disc

DimensionD*T*A(mm)	DimensionD*T*A(inch)	Shape	Speed(R.P.M.)	Speed(m/s)	PCS/Shrink wrap	PCS/Inner box	PCS/Outer carton
105x1.0x16	4x1/25x5/8	T41	15200	80	25	50	800
105x1.2x16	4x3/64x5/8	T41	15200	80	25	50	800
105x1.6x16	4x1/16x5/8	T41	15200	80	25	50	800
115x1.0x22.2	4 1/2x1/25x7/8	T41	13300	80	25	25	400
115x1.2x22.2	4 1/2x3/46x7/8	T41	13300	80	25	25	400
115x1.6x22.2	4 1/2x1/16x7/8	T41	13300	80	25	25	400
125x1.0x22.2	5x1/25x7/8	T41	12200	80	25	25	400
125x1.2x22.2	5x3/64x7/8	T41	12200	80	25	25	400
125x1.6x22.2	5x1/16x7/8	T41	12200	80	25	25	400



## Multifunctional cutting and grinding disc

- Combines cutting and grinding functions
- Excellent performance
- Top raw materials
- Cost effective

### Application

- Stainless steel/INOX
- Iron
- Welding seams
- Angular steel profiles
- High alloy special steel
- Solid steel bar
- Very solid construction steel
- Unalloyed and alloyed construction steel

EN12413

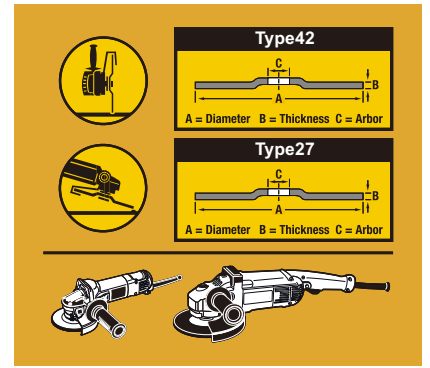

### Multifunctional cutting and grinding disc



Dimension D*T*A(mm)	Dimension D*T*A(inch)	Shape	Speed(R.P.M.)	Speed(m/s)	PCS/Shrink wrap	PCS/Inner box	PCS/Outer carton
100x3.0x16	4x1/8x5/8	T42/T27	15200	72/80	10	50	400
115x3.0x22.2	4 1/2x1/8x7/8	T42/T27	13300	72/80	10	50	200
125x3.0x22.2	5x1/8x7/8	T42/T27	12200	72/80	10	50	200
150x3.0x22.2	6x1/8x7/8	T42/T27	10200	72/80	10	50	200
180x3.0x22.2	7x1/8x7/8	T42/T27	8500	72/80	20	50	200



## · Rail cutting disc ★★★★★

- Specially designed for railway construction
- Stable performance in any operating environment

### Application

- Suitable for most types of gasoline saws on the market
- Widely used for cutting 60 and 75 rails

EN12413

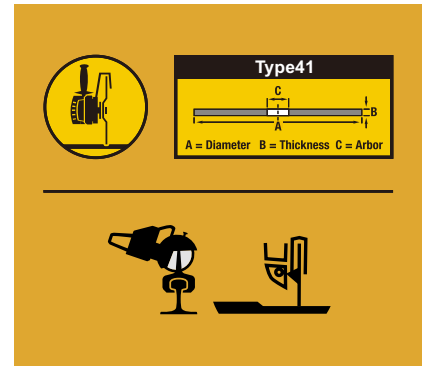

### Rail cutting disc

DimensionD*T*A(mm)	DimensionD*T*A(inch)	Shape	Speed(R.P.M.)	Speed(m/s)	PCS/Shrink wrap	PCS/Inner box
355x4.0x25.4	14x5/32x1	T41	4400	80	5	25
405x4.0x25.4	16x5/32x1	T41	3800	80	5	25



## · Stone cutting disc

- Very long durability
- Easy working
- Cost effective
- Fast cutting

## Application

- Granite materials
- Concrete
- Curbstone

**EN12413**

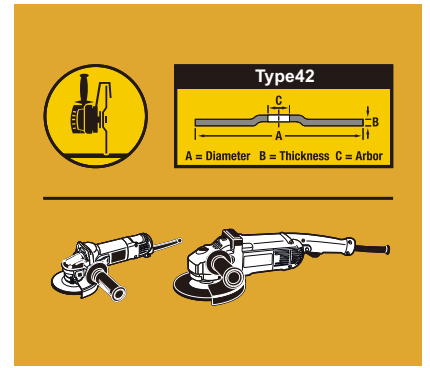

### Stone cutting disc

DimensionD*T*A(mm)	DimensionD*T*A(inch)	Shape	Speed(R.P.M.)	Speed(m/s)	PCS/Shrink wrap	PCS/Inner box	PCS/Outer carton
115x3.2x22.2	4 1/2x1/8x7/8	T42	13300	80	10	50	200
125x3.2x22.2	5x1/8x7/8	T42	12200	80	10	50	200
150x3.2x22.2	6x1/8x7/8	T42	10200	80	10	50	200
180x3.2x22.2	7x1/8x7/8	T42	8500	80	20	50	200



# Grinding disc

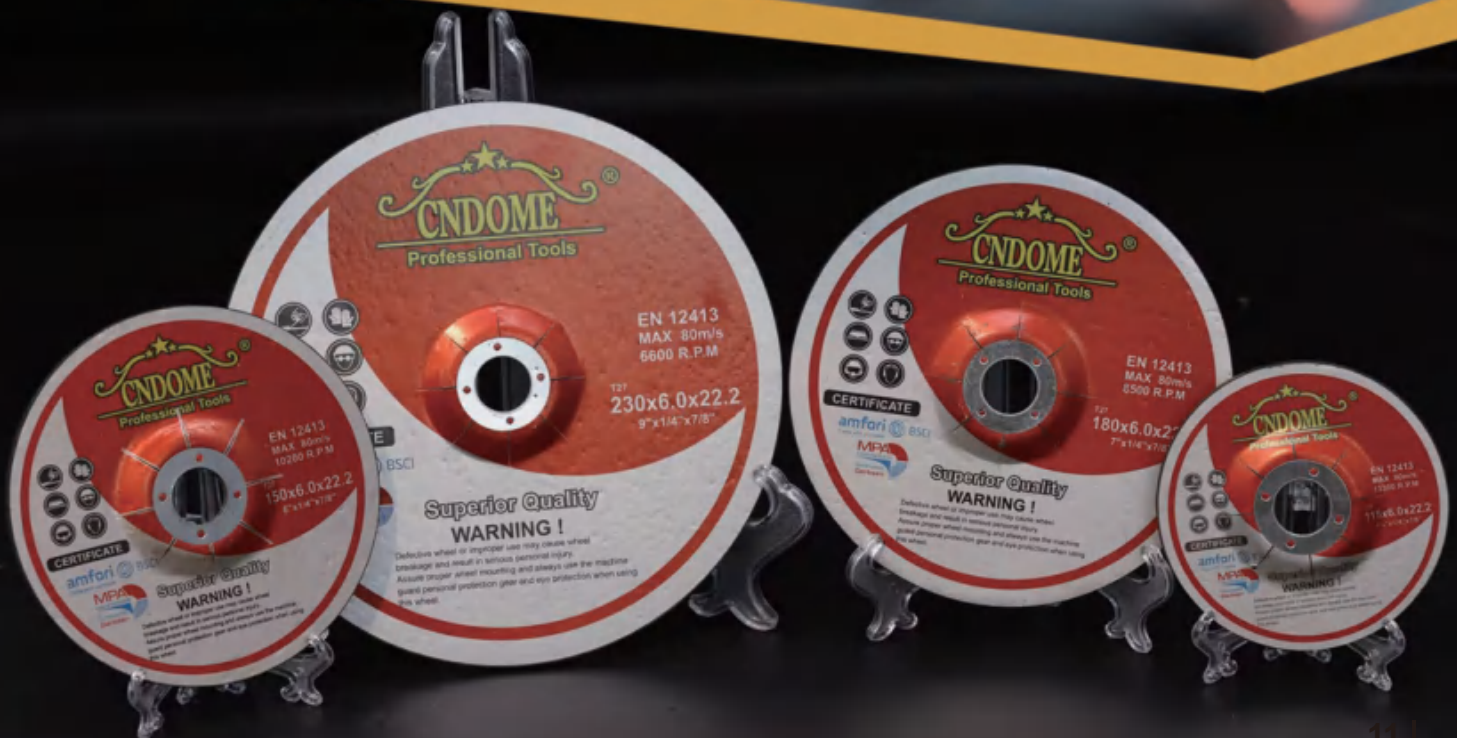

## Full size grinding disc

- High performance aluminum oxide grain for long life and high material removal
- Low vibration design ensures operator convenience and longer usage
- Triple fiberglass reinforcement provides added strength for aggressive stock removal

## Application

- Stainless steel/INOX
- Tool steel
- Welding seams
- Non-ferrous metals
- High alloy special steel
- Sheet steel
- Very solid construction steel
- Unalloyed and alloyed construction steel

**EN12413**

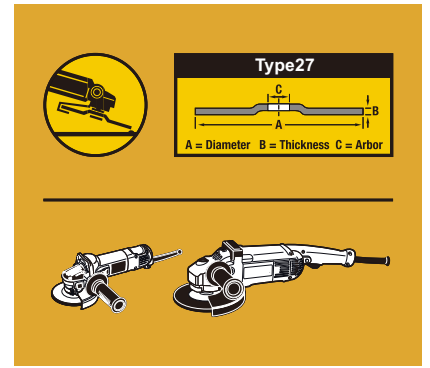

## Full size grinding disc



DimensionD*T*A(mm)	DimensionD*T*A(inch)	Shape	Speed(R.P.M.)	Speed(m/s)	PCS/Shrink wrap	PCS/Inner box	PCS/Outer carton
50x4.0x10	2x5/32x3/8	T27	20100	72/80	5	25	400
58x4.0x10	2x5/32x3/8	T27	20100	72/80	5	25	400
76x4.0x10	3x5/32x3/8	T27	20100	72/80	5	25	400
100x4.0x16	4x5/32x5/8	T27	15200	72/80	5	25	400
100x6.0x16	4x1/4x5/8	T27	15200	72/80	5	25	200
100x8.0x16	4x5/16x5/8	T27	15200	72/80	5	25	200
115x6.0x22.2	4 1/2x1/4x7/8	T27	13300	72/80	5	25	100
125x6.0x22.2	5x1/4x7/8	T27	12200	72/80	5	25	100
150x6.0x22.2	6x1/4x7/8	T27	10200	72/80	5	25	100
180x6.0x22.2	7x1/4x7/8	T27	8500	72/80	5	25	50
230x6.0x22.2	9x1/4x7/8	T27	6600	72/80	5	25	50



## · Flexible disc

- The hollow shape of the working surface ensures a long service life of the grinding wheel and avoids clogging or loading
- Different grit sizes are available for different working environments and materials used

### Application

- Stainless steel/INOX
- Tool steel
- Welding seams
- Non-ferrous metals
- High alloy special steel
- Sheet steel
- Very solid construction steel
- Unalloyed and alloyed construction steel

**EN12413**

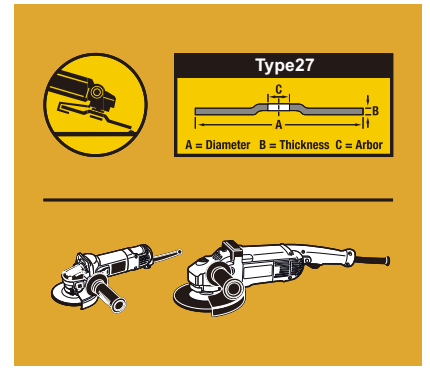

### Flexible disc

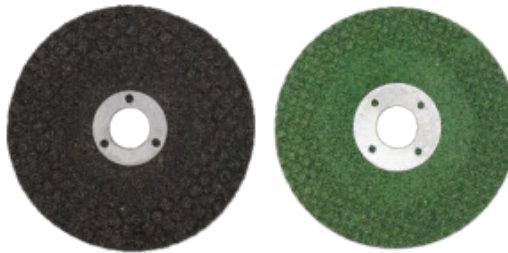

DimensionD*T*A(mm)	DimensionD*T*A(inch)	Shape	Speed(R.P.M.)	Speed(m/s)	PCS/Shrink wrap	PCS/Inner box	PCS/Outer carton
50x4.0x10	2x1/8x3/8	T27	20100	72/80	10	50	400
58x4.0x10	2x1/8x3/8	T27	20100	72/80	10	50	400
76x4.0x10	3x1/8x3/8	T27	20100	72/80	10	50	400
100x3.0x16	4x1/8x5/8	T27	15200	72/80	10	50	400
125x3.0x22.2	5x1/8x7/8	T27	12200	72/80	10	50	200
150x3.0x22.2	6x1/8x7/8	T27	10200	72/80	10	50	200
180x3.0x22.2	7x1/8x7/8	T27	8500	72/80	20	20	100

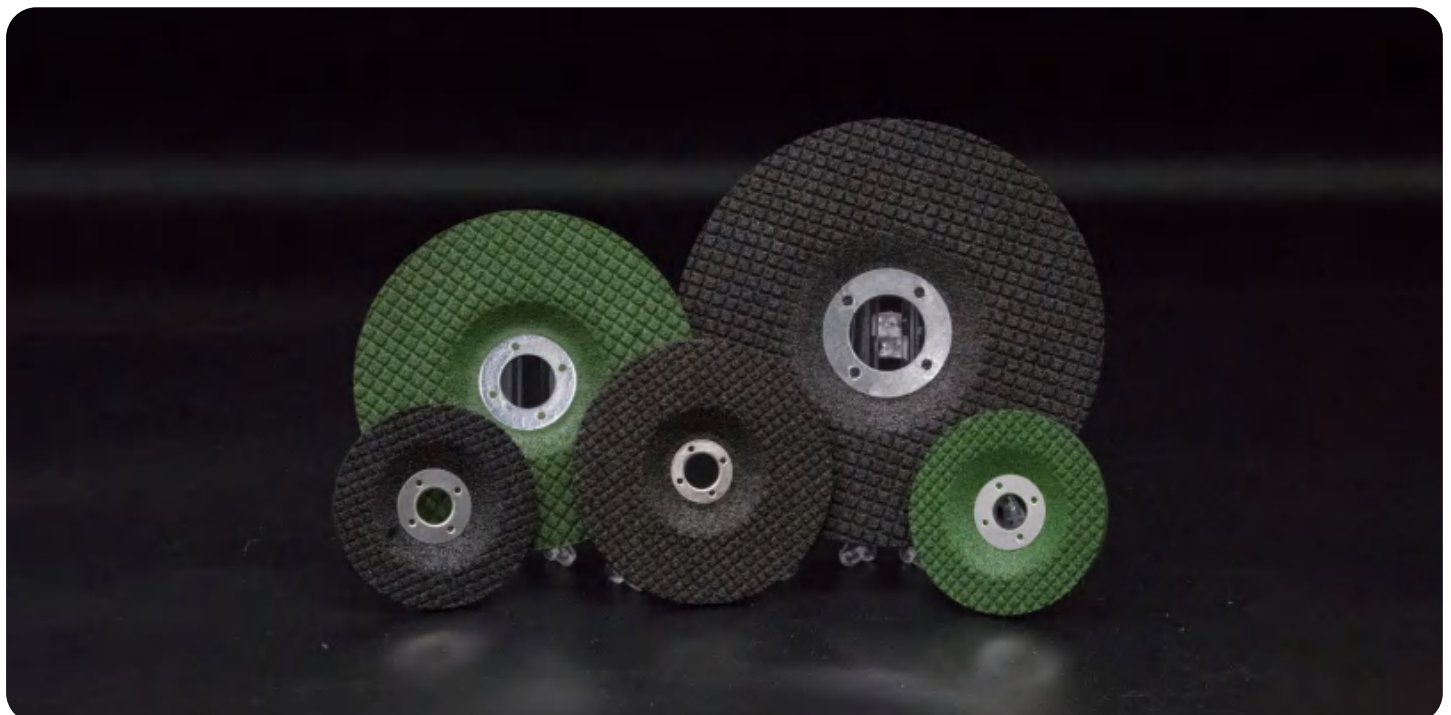

# Flap Disc

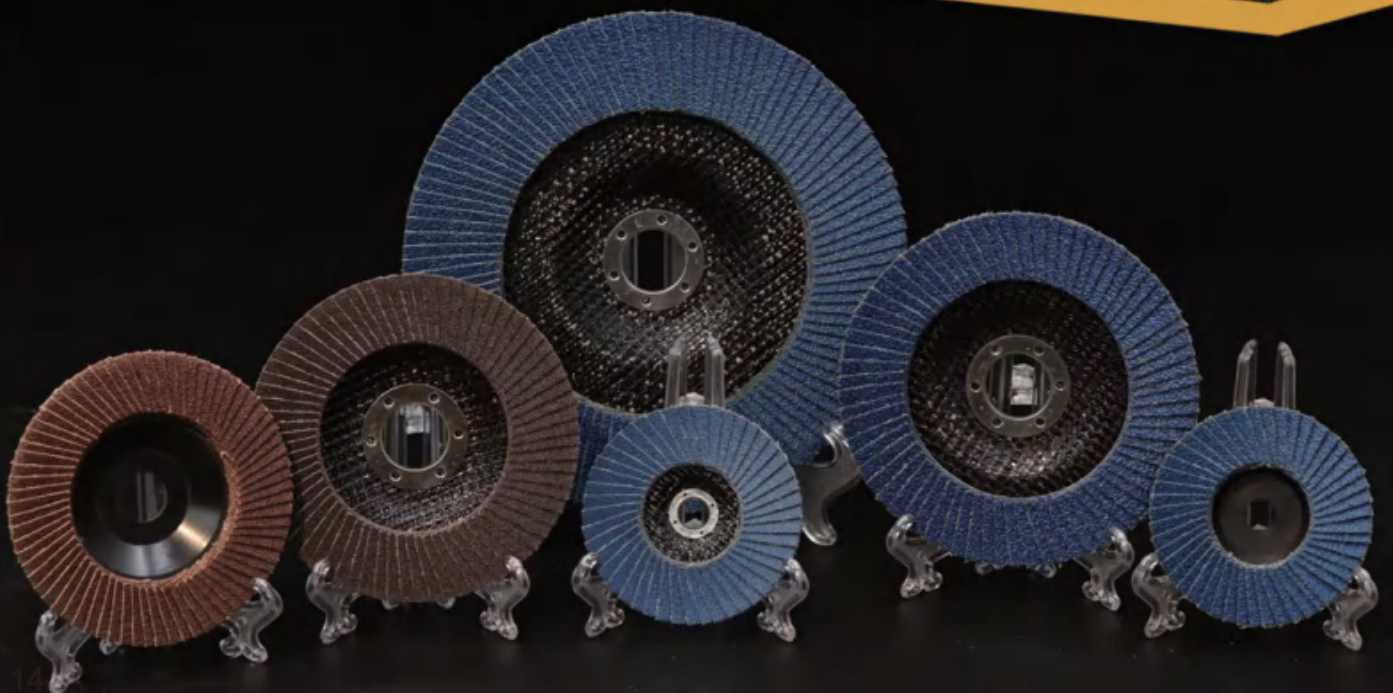



## Full size flap disc

- Adopt high-standard fiberglass cover to ensure efficient and safe operation at high speeds
- High-quality sandpapers bring more stable and efficient grinding
- Excellent at a variety of tasks including surface blending, beveling, grinding, deburring, edge chamfering, finishing, deburring and rust removal

**EN12413**



### Cover

- Plastic cover
- Mesh cover
- Iron cover
- Nylon cover

### Abrasive

- Aluminum oxide
- Zirconia

**Type27**

• Ideal working angle of less than 15°

---

**Type29**

• Ideal working angle of 15°-35°

## Full size flap disc

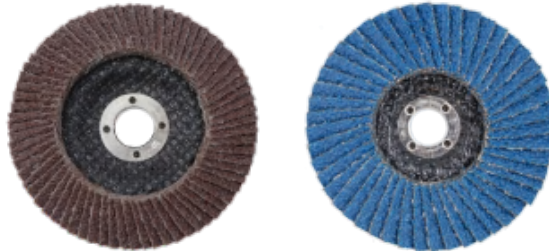

DimensionD*T*A(mm)	DimensionD*T*A(inch)	Shape	Speed(R.P.M.)	Speed(m/s)	Grit size(#)	PCS/Shrink wrap	PCS/Outer carton
58x10	2x3/8	T27/T29	15200	80	40/60/80/120	5	200
75x10	3x3/8	T27/T29	13300	80	40/60/80/120	5	200
100x16	4x5/8	T27/T29	15200	80	40/60/80/120	5	200
115x22	4 1/2x7/8	T27/T29	13300	80	40/60/80/120	5	200
125x22	5x7/8	T27/T29	12200	80	40/60/80/120	5	200
180x22	7x7/8	T27/T29	8500	80	40/60/80/120	5	50



Different grit represent the roughness of the particles



40 grit



60 grit



80 grit



120 grit

## Mini model

- The 2-inch and 3-inch small models are very popular in DIY and small space operations
- Suitable for various handheld small angle grinders, easy to operate
- High-quality raw materials also give them powerful cutting and grinding capabilities

## Application

- Stainless steel/INOX
- Iron
- Welding seams
- Angular steel profiles
- High alloy special steel
- Solid steel bar
- Very solid construction steel
- Unalloyed and alloyed construction steel

**EN12413**

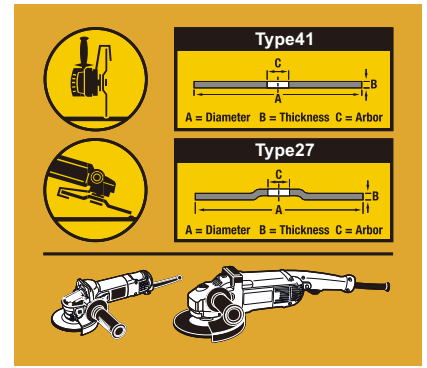

### Mini model-cutting disc



DimensionD*T*A(mm)	DimensionD*T*A(inch)	Shape	Speed(R.P.M.)	Speed(m/s)	PCS/Shrink wrap	PCS/Inner box	PCS/Outer carton
50x1.0x10	2x1/24x3/8	T41	20100	80	25	50	800/1200
58x1.0x10	2x1/24x3/8	T41	20100	80	25	50	800/1200
75x0.8x10	3x1/32x3/8	T41	20100	80	25	50	800/1200
75x1.0x10	3x1/24x3/8	T41	20100	80	25	50	800/1200
75x1.6x10	3x1/16x3/8	T41	20100	80	25	50	800/1200

### Mini model-grinding disc



DimensionD*T*A(mm)	DimensionD*T*A(inch)	Shape	Speed(R.P.M.)	Speed(m/s)	PCS/Shrink wrap	PCS/Inner box	PCS/Outer carton
50x4.0x10	2x5/32x3/8	T27	20100	72/80	5	25	400
58x4.0x10	2x5/32x3/8	T27	20100	72/80	5	25	400
76x4.0x10	3x5/32x3/8	T27	20100	72/80	5	25	400



Mini model-flexible disc

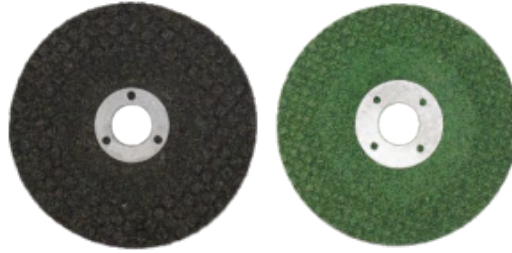

DimensionD*T*A(mm)	DimensionD*T*A(inch)	Shape	Speed(R.P.M.)	Speed(m/s)	PCS/Shrink wrap	PCS/Inner box	PCS/Outer carton
50x3.0x10	2x1/8x3/8	T27	20100	72/80	10	50	400
58x3.0x10	2x1/8x3/8	T27	20100	72/80	10	50	400
76x3.0x10	3x1/8x3/8	T27	20100	72/80	10	50	400

Mini model-flap disc

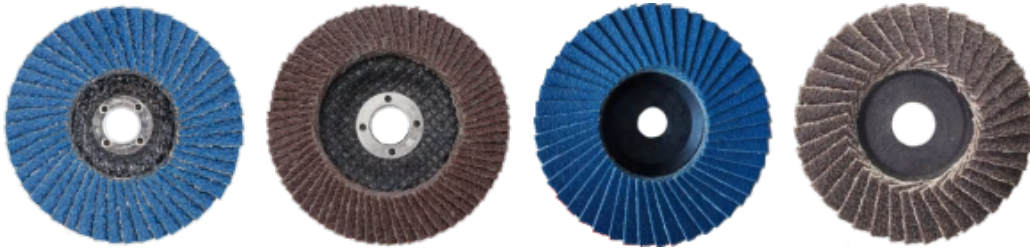

DimensionD*T*A(mm)	DimensionD*T*A(inch)	Shape	Speed(R.P.M.)	Speed(m/s)	Grit size(#)	PCS/Shrink wrap	PCS/Outer carton
58x10	2x3/8	T27/T29	15200	80	40/60/80/120	5	200
75x10	3x3/8	T27/T29	13300	80	40/60/80/120	5	200

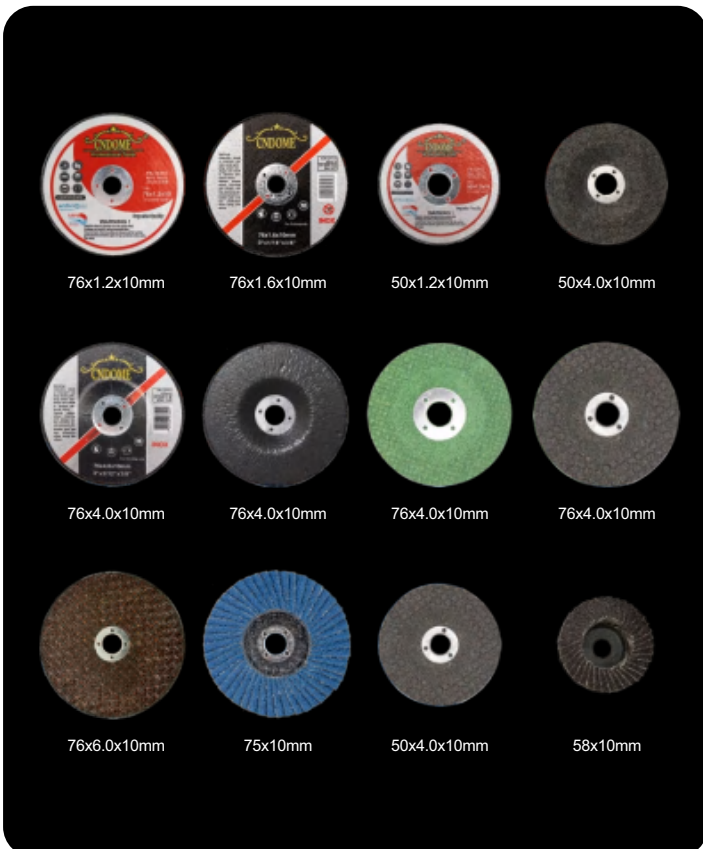

### Inner box

- All shrink
- White box
- Plastic drums
- Vacuum forming
- Kraft box
- Tin box

### Outer carton

- Kraft carton
- Colorful carton



## Our shipments go all over the world







## Production Equipment



***DOME***  
since2001

With a modern workshop of 20,000 square meters ■

The molding workshop can perfectly achieve constant control of temperature and humidity ■



# **DOME**

since2001

## Testing Environment and Equipment

Consistent product quality, based on thorough testing

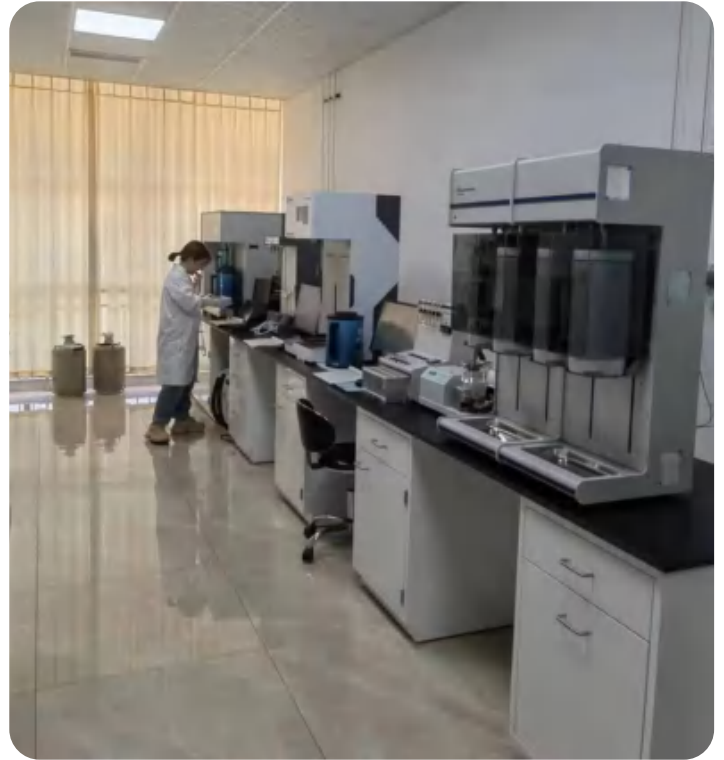

# **DOME** since 2001

**Changzhou Dome Abrasives Manufacture Co.,Ltd**



ADD: Garden Industrial Park, Zhenglu Town, Tianning District, Changzhou City, Jiangsu Province, China  
[www.czdome.com](http://www.czdome.com)